

Handwritten: PART OF
**PHASE STRATA PLAN OF LOT 1,
 SEC. 7, TP. 2, N.W.D.,
 PLAN 78000**
 RE: BOUNDARY
 SEE PLAN LMP19751

FIRST SHEET: Sheet 1 of 13 Sheets
STRATA PLAN NW 3143

PHASE I
 Deposited and Registered in
 the Land Title Office at
 New Westminster, B.C. this 15
 day of Jan 1989.

MUNICIPALITY OF SURREY
 15 0 15 30 45
 GRAPHIC SCALE - 1:750
 All distances are in metres.

Handwritten: D. G. Huxley
 Registrar
 Reference no. AD13202 to AD13224

LEGEND:
 LCP DENOTES LIMITED COMMON
 PROPERTY
 © DENOTES COMMON PROPERTY
 S.L. DENOTES STRATA LOT
 sqm DENOTES SQUARE METRES

THE ADDRESS FOR SERVICE OF
 DOCUMENTS ON THE STRATA
 CORPORATION IS:

THE OWNERS,
 STRATA PLAN NW 3143
 c/o PRYKE, LAMBERT, LEATHLEY,
 RUSSELL
 #500 NORTH TOWER
 5811 COONEY ROAD
 RICHMOND, B.C. V6X 3M1

CIVIC ADDRESS:
 SL 1 to SL 9 and SL 11 to 16
 6211 Boundary Drive West
 SL 10 6223
 SL 17 6225
 SL 18 6227
 SL 19 6233
 SL 20 6235
 SL 21 6245
 SL 22 6247
 SL 23 6249 Boundary Drive West
 Surrey, B.C.

Handwritten: Declaration of Intention
 to create a Strata Plan
 by Phase Development
 (Form E) Filed 15.01.90
 under AD13201

I, D.G.Huxley, of Abbotsford,
 a British Columbia Land
 Surveyor, hereby certify that
 the buildings erected on the
 parcel described above lie
 wholly within the external
 boundaries of that parcel.
 Dated at Surrey, B.C., this
15th day of December 1989.

Handwritten: D. G. Huxley
 B.C.L.S.

Cameron and Associates
 B.C. Land Surveyors
 Unit 8-15243-91st Ave
 Surrey, B.C. V3R 8P8
 Phone: 588-0241
 Fax: 581-8870

This plan lies within the Greater
 Vancouver Regional District.

FILE: 89-A-2747

BUILDING DIMENSIONS AND LOCATION

First Sheet Sheet 2 of 13 Sheets

STRATA PLAN NW 3143

PHASE I

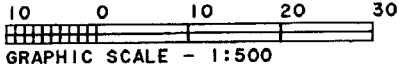

NOTE:
DIMENSIONS SHOWN ARE TO
BUILDING OUTLINE

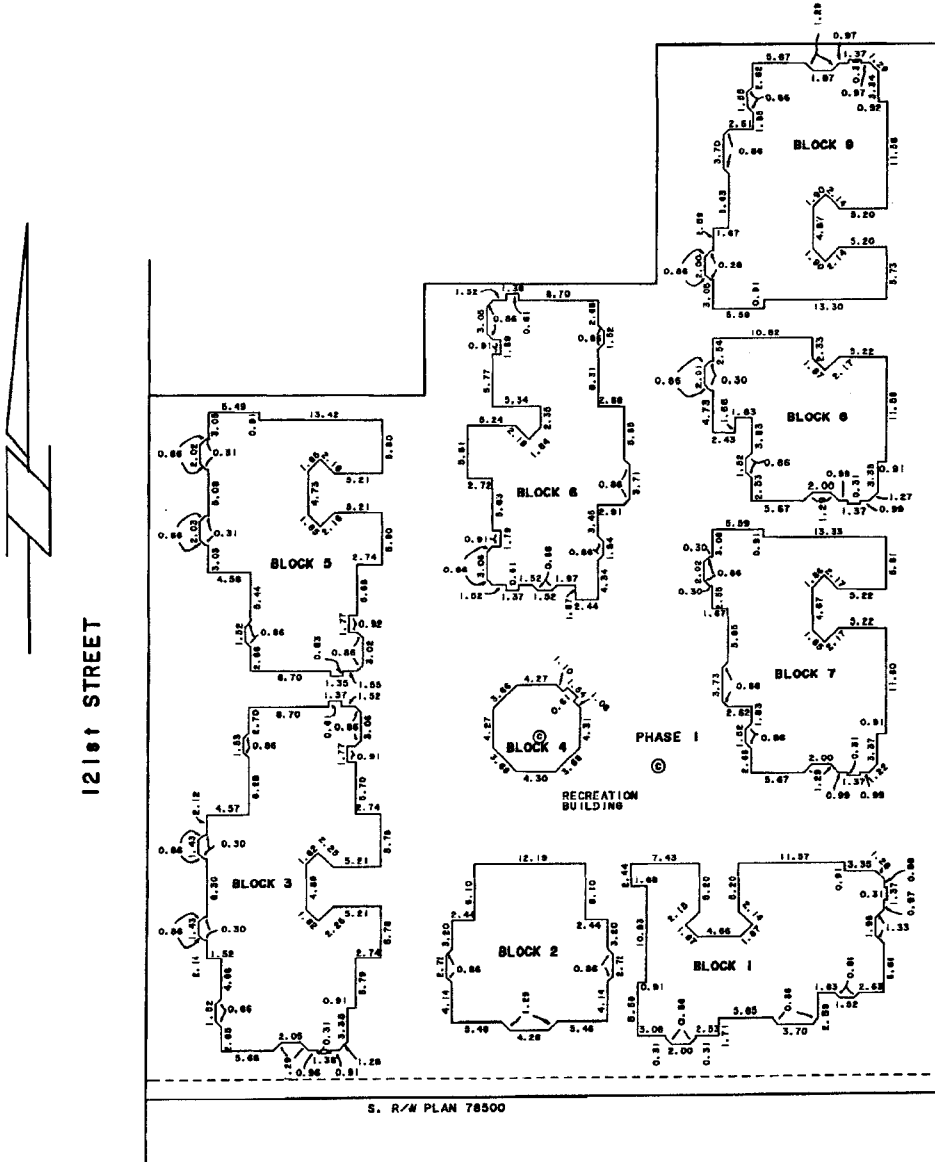

DATED THIS 15th DAY OF
December, 1989.

D.H. B.C.L.S.
FILE: 89-A-2747

CONDOMINIUM ACT

Second Sheet, Sheet 3 of 13 Sheets

STRATA PLAN NW 3143
PHASE I

STRATA LOT NO.	BLOCK NO.	SHEET NO.	AREA (sqm)	FORM 1	FORM 2
				SCHEDULE OF UNIT ENTITLEMENT UNIT ENTITLEMENT	SCHEDULE OF INTEREST UPON DESTRUCTION INTEREST UPON DESTRUCTION
1	1	4	203.2	20	226
2	1	4	185.2	19	205
3	1	4	199.7	20	220
4	2	5	187.2	19	204
5	2	5	188.5	19	204
6	3	6	203.8	20	226
7	3	6	190.5	19	210
8	3	6	190.3	19	210
9	3	6	204.8	20	229
10	7	9	204.6	20	226
11	5	7	204.4	20	230
12	5	7	200.6	20	220
13	5	7	200.5	20	220
14	b	8	207.3	21	229
15	b	8	186.3	19	205
16	b	8	204.8	20	229
17	7	9	186.0	19	205
18	7	9	199.6	20	221
19	8	10	204.0	20	226
20	8	10	200.7	20	221
21	q	11	198.8	20	221
22	q	11	187.5	19	205
23	q	11	203.2	20	226
AGGREGATE			4541.9	453	5018

Accepted as to Forms 1 and 2
this 24 day of December 1989.

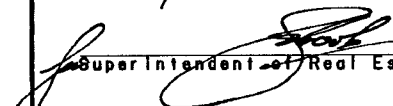
Superintendent of Real Estate

STATUTORY DECLARATION

We, the undersigned do solemnly declare that:

- 1) We, the undersigned are the Owner-Developer;
- 2) The strata plan is entirely for residential use.

We make this solemn declaration conscientiously believing it to be true and knowing that it is of the same force and effect as if made under oath.



Declared before me at Richmond
this 20 day of December 1989.

A Commissioner for taking affidavits within the Province of British Columbia.

Approved as Phase I of a 2 Phase Strata Plan under the Condominium Act, this 11 day of January 1990.

Municipal Approving Officer for the Municipality of Surrey

OWNER:
CARTWRIGHT HOLDINGS LTD.
(INCORPORATION NO. 113813)

AUTHORIZED SIGNATORY

AUTHORIZED SIGNATORY

MORTGAGEE:
S-244 HOLDINGS LTD.
(INC. NO. 352227)

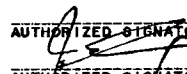

AUTHORIZED SIGNATORY

AUTHORIZED SIGNATORY

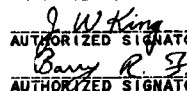
VANCOUVER CITY SAVINGS CREDIT UNION

AUTHORIZED SIGNATORY

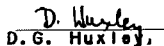
I, D.G. Huxley, of Abbotsford, B.C., a British Columbia Land Surveyor, hereby certify that the buildings shown in this strata plan have not, as of the 14 day of December, 1989, been previously occupied. Dated at Surrey, B.C., this 15 day of December, 1989.

D.G. Huxley, B.C.L.S.

File: 89-A-2747

FLOOR PLANS & CROSS-SECTION

Sheet 4 of 13 Sheets

STRATA PLAN NW3143

PHASE I



BLOCK I
FIRST FLOOR

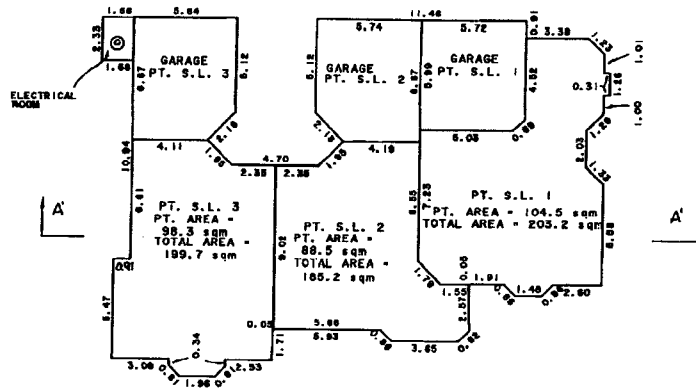

SECOND FLOOR

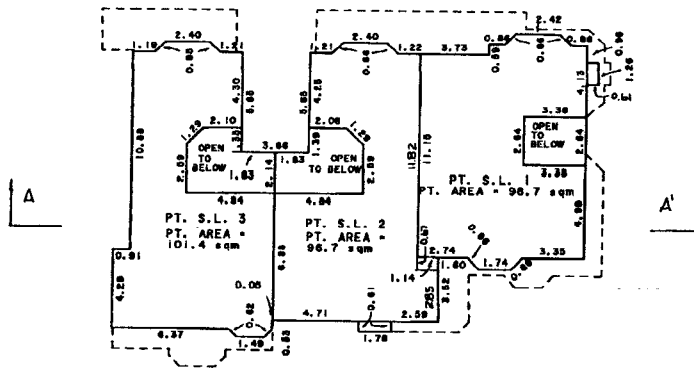

SECTION A - A'

PT. S.L. 3	PT. S.L. 2	PT. S.L. 1
PT. S.L. 3	PT. S.L. 2	PT. S.L. 1
⊙	⊙	⊙

SECOND FLOOR

GROUND FLOOR

CRAWL SPACE

DATED THIS 12TH DAY OF
December, 1989.

D.H. B.C.L.S.

FILE: 89-A-2784

FLOOR PLANS & CROSS-SECTION

Sheet 5 of 13 Sheets

STRATA PLAN NW 3143

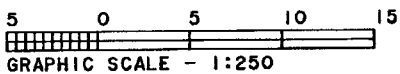

PHASE I

BLOCK 2

FIRST FLOOR

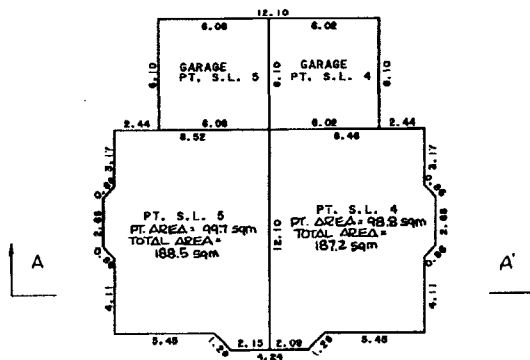

SECOND FLOOR

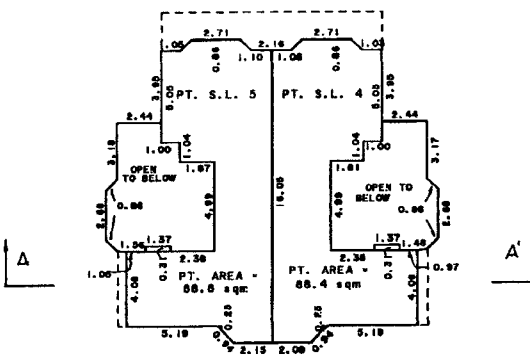

SECTION A - A'

PT. SL. 5	PT. SL. 4
PT. SL. 5	PT. SL. 4
⊗	⊗

SECOND FLOOR
GROUND FLOOR
CRAWL SPACE

DATED THIS 15th DAY OF
December, 1989.

D. Harley B.C.L.S.
FILE: 89-A-2747

FLOOR PLANS & CROSS-SECTION

Sheet 6 of 13 Sheets

STRATA PLAN NW 3143

PHASE I

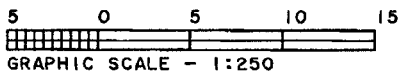

BLOCK 3

FIRST FLOOR

SECOND FLOOR

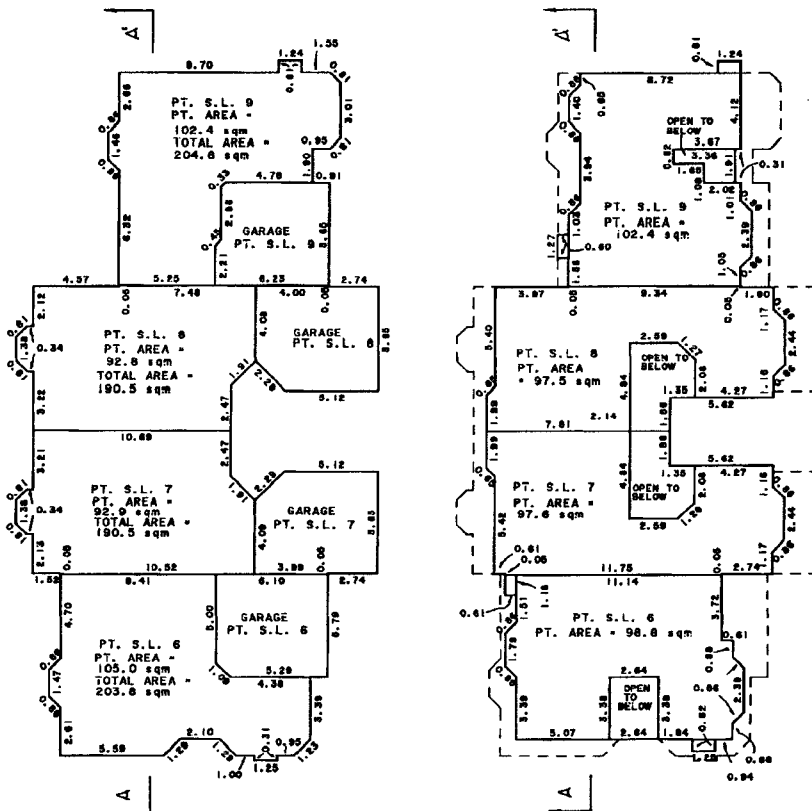

SECTION A - A'

PT. S.L. 6	PT. S.L. 7	PT. S.L. 8	PT. S.L. 9
PT. S.L. 6	PT. S.L. 7	PT. S.L. 8	PT. S.L. 9
⊙	⊙	⊙	⊙

SECOND FLOOR

GROUND FLOOR

CRAWL SPACE

DATED THIS 15th DAY OF December 1989.

D. M. ... B. C. L. S.

FILE: 89-A-2747

Plan #: NWS3143 App #: N/A Ctr #: (Altered)

RCVD: 1998-02-12 RQST: 2013-1-18 21:16:02

FLOOR PLANS & CROSS-SECTION

Sheet 7 of 13 Sheets

STRATA PLAN NW 3143

PHASE I



BLOCK 5
FIRST FLOOR

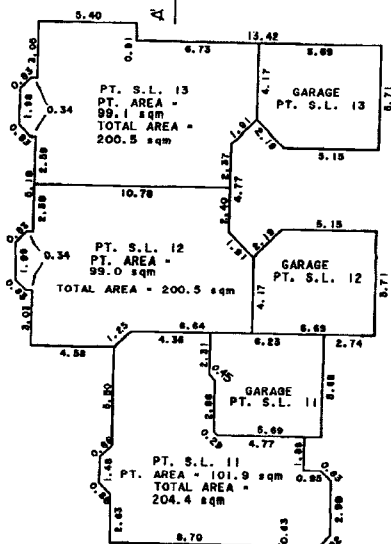

SECOND FLOOR

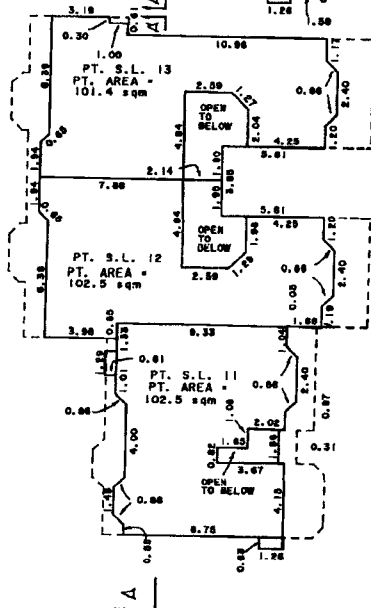

SECTION A - A'

PT. S.L. 11	PT. S.L. 12	PT. S.L. 13
PT. S.L. 11	PT. S.L. 12	PT. S.L. 13
⊙	⊙	⊙

SECOND FLOOR
GROUND FLOOR
CRAWL SPACE

DATED THIS 15th DAY OF
December, 1989.

D.W. B.C.L.S.

FILE: 89-A-2747

Plan #: NWS3143 App #: N/A Cht #: (Altered)

RCVD: 1998-02-12 ROST: 2013-11-18 21:16:02

FLOOR PLANS & CROSS-SECTION

Sheet 8 of 13 Sheets
STRATA PLAN NW 3143

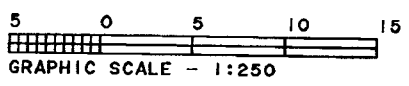

PHASE I

BLOCK 6

GROUND FLOOR

SECOND FLOOR

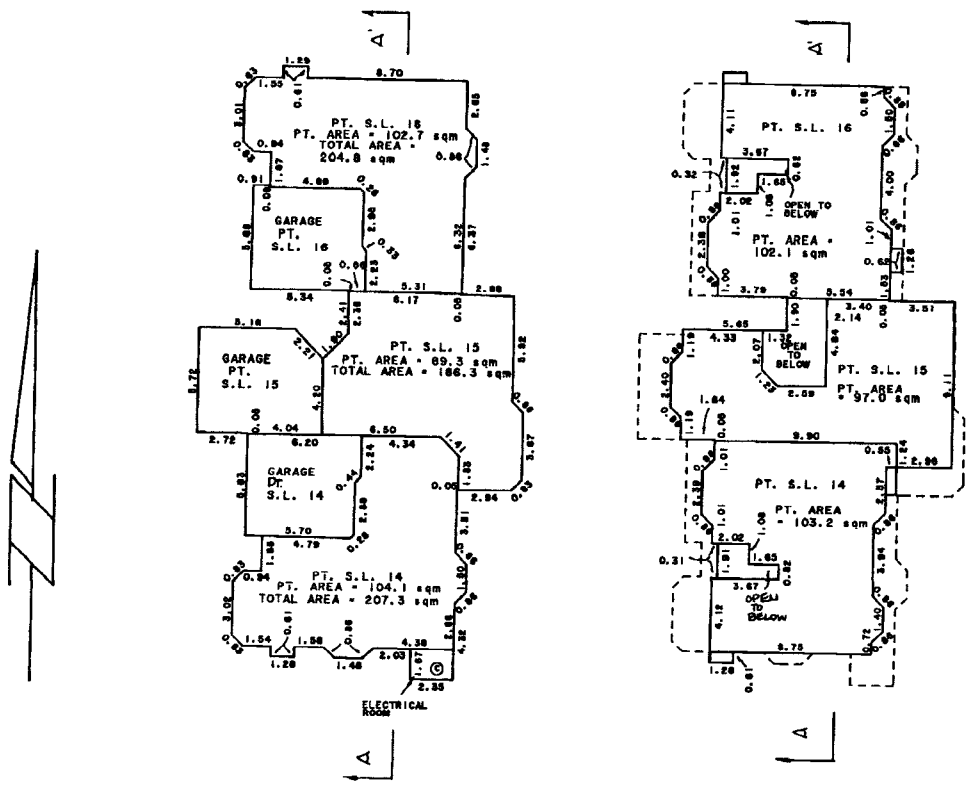

SECTION A - A'

PT. S.L. 14	PT. S.L. 15	PT. S.L. 16
PT. S.L. 14	PT. S.L. 15	PT. S.L. 16
⊙	⊙	⊙

SECOND FLOOR
GROUND FLOOR
CRAWL SPACE

DATED THIS 15th DAY OF December, 1989.

DH B. C. L. S.

FILE: 89-A-2747

Plan # NWS3143 App # N/A Crt # (Altered)

RCVD: 1998-02-12 RQST: 2013-11-18 21:16:02

FLOOR PLANS & CROSS-SECTION

Sheet 9 of 13 Sheets

STRATA PLAN NW 3143

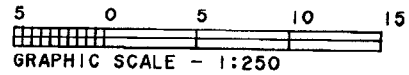

PHASE I

BLOCK 7

FIRST FLOOR

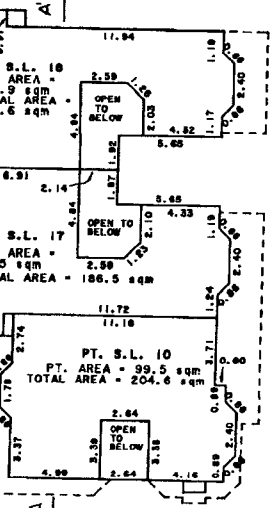
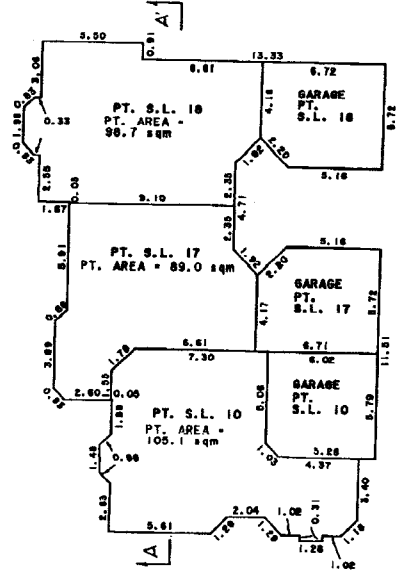

SECOND FLOOR

PT. S.L. 10	PT. S.L. 17	PT. S.L. 18
PT. S.L. 10	PT. S.L. 17	PT. S.L. 18
⊙	⊙	⊙

SECTION A - A'

SECOND FLOOR
GROUND FLOOR
CRAWL SPACE

DATED THIS 15th DAY OF December, 1989.

D.W. B.C.L.S.

FILE: 89-A-2747

Plan #: NWS3143 App #: N/A Cht #: (Altered)

RCVD: 1998-02-12 RQST: 2013-11-18 21:16:02

FLOOR PLANS & CROSS-SECTION

Sheet 11 of 13 Sheets

STRATA PLAN NW 3143

PHASE I



BLOCK 9

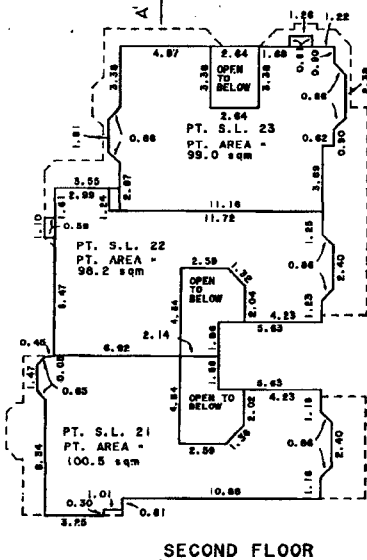
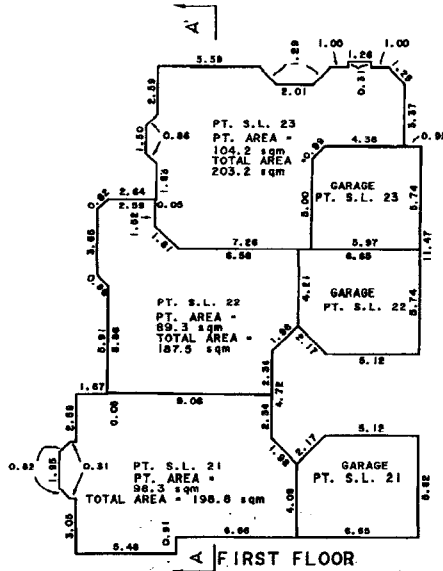

PT. SL. 21	PT. SL. 22	PT. SL. 23
PT. SL. 21	PT. SL. 22	PT. SL. 23
⊙	CRAWL	⊙
		SPACE

SECOND FLOOR
GROUND FLOOR
CRAWL SPACE

SECTION A - A'

DATED THIS 15th DAY OF
December, 1989.

D.H. B.C.L.S.
FILE: 89-A-2747

AMENDED SHEET 1

PHASED STRATA PLAN OF LOT 1 EXCEPT:
PHASE 1, STRATA PLAN NW 3143,
SEC. 7, TP. 2, N.W.D., PLAN 78000

CITY OF SURREY

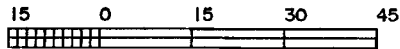

GRAPHIC SCALE - METERS 1:750

All distances are in metres

AMENDED
FIRST SHEET: Sheet 1 of 12 Sheets
STRATA PLAN NW 3143

PHASE 2

Deposited and Registered in the Land
Title Office at New Westminster,
B.C., this _____ day of _____ 1993.

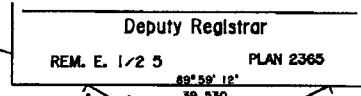
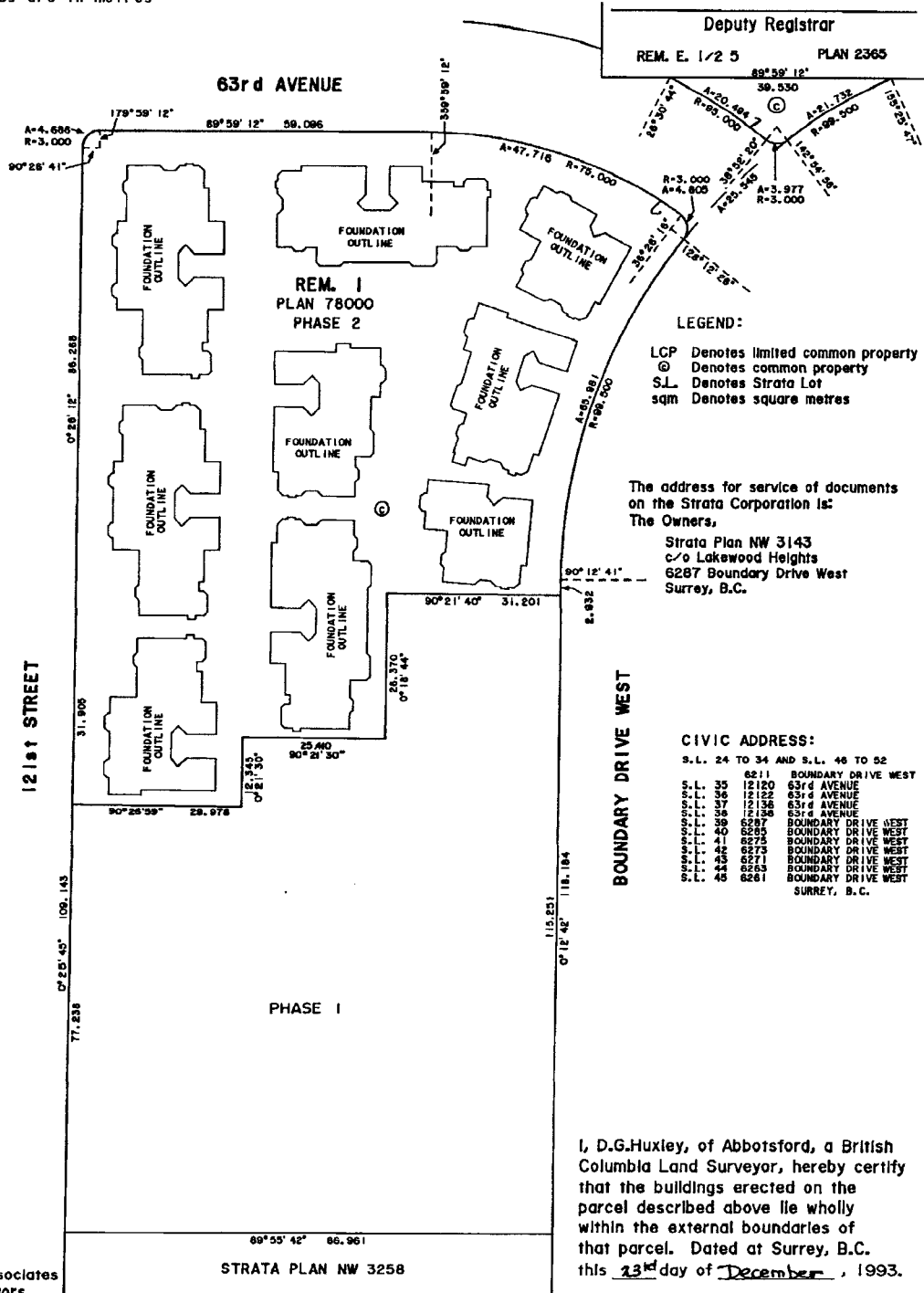

LEGEND:
LCP Denotes limited common property
© Denotes common property
S.L. Denotes Strata Lot
sqm Denotes square metres

The address for service of documents
on the Strata Corporation is:
The Owners,
Strata Plan NW 3143
c/o Lakewood Heights
6287 Boundary Drive West
Surrey, B.C.

CIVIC ADDRESS:

S.L. 24	TO 34	AND S.L. 46	TO 52
S.L. 35	6211	BOUNDARY DRIVE WEST	
S.L. 36	12120	63rd AVENUE	
S.L. 37	12122	63rd AVENUE	
S.L. 38	12136	63rd AVENUE	
S.L. 39	12138	63rd AVENUE	
S.L. 40	6287	BOUNDARY DRIVE WEST	
S.L. 41	6285	BOUNDARY DRIVE WEST	
S.L. 42	6275	BOUNDARY DRIVE WEST	
S.L. 43	6273	BOUNDARY DRIVE WEST	
S.L. 44	6271	BOUNDARY DRIVE WEST	
S.L. 45	6263	BOUNDARY DRIVE WEST	
S.L. 46	6261	BOUNDARY DRIVE WEST	

SURREY, B.C.

I, D.G.Huxley, of Abbotsford, a British
Columbia Land Surveyor, hereby certify
that the buildings erected on the
parcel described above lie wholly
within the external boundaries of
that parcel. Dated at Surrey, B.C.
this 23rd day of December, 1993.

D. Huxley B.C.L.S.
FILE: 89-A-2747-20

Cameron and Associates
B.C. Land Surveyors
Unit 103-8431-160th St.
Surrey, B.C. V3S 3T9
Phone: 597-3777
Fax: 597-3783

STRATA PLAN NW 3258

This plan lies within the Greater
Vancouver Regional District.

Plan #: NWS3143 App #: N/A Crt #: (Altered)

RCVD: 1998-02-12 RQST: 2013-11-18 21:16:02

BUILDING DIMENSIONS AND LOCATION

First Sheet Sheet 2 of 12 Sheets

STRATA PLAN NW 3143

PHASE 2



DIMENSIONS SHOWN ARE TO BUILDING OUTLINE

63rd AVENUE

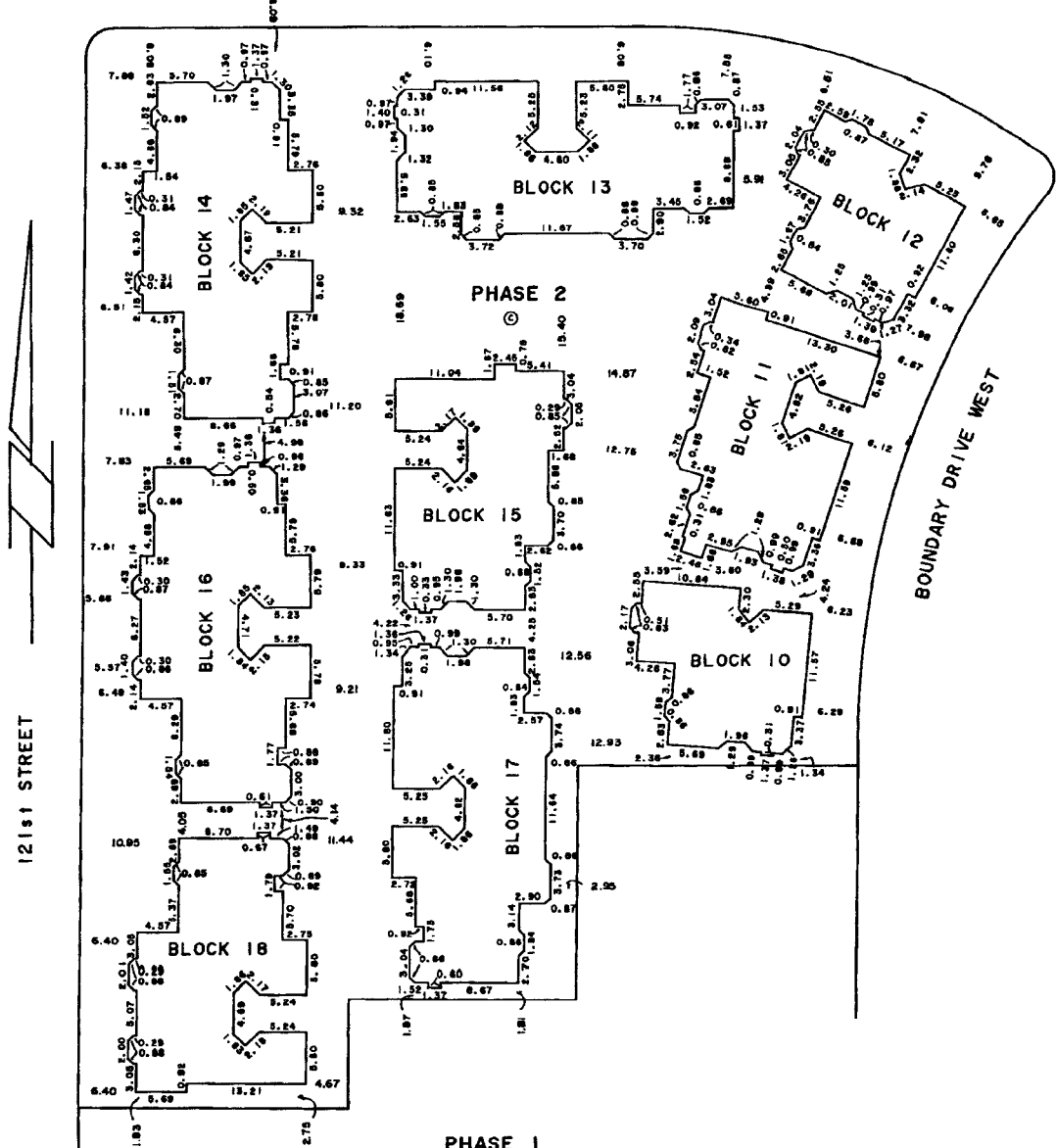

DATED THIS 17th DAY OF May, 1990.

D. M. Kelly B. C. L. S.
FILE: 89-A-2747-30

Plan #: NWS3143 App #: N/A Ctl #: (Altered)

RCVD: 1998-02-12 ROST: 2013-1-18 21:16:02

CONDOMINIUM ACT

Second Sheet, Sheet 3 of 12 Sheets

STRATA PLAN NW 3143

PHASE 2

STRATA LOT NO.	BLOCK NO.	SHEET NO.	AREA (sqm)	FORM 1	FORM 2
				SCHEDULE OF UNIT ENTITLEMENT UNIT ENTITLEMENT	SCHEDULE OF INTEREST UPON DESTRUCTION INTEREST UPON DESTRUCTION
24	16	10	204.4	20	229
25	16	10	190.9	19	210
26	16	10	192.5	19	210
27	16	10	204.8	20	226
28	15	9	204.3	20	226
29	15	9	186.6	19	205
30	15	9	198.6	20	220
31	14	8	204.4	20	229
32	14	8	190.9	19	210
33	14	8	192.5	19	210
34	14	8	204.8	20	226
35	13	7	204.8	20	226
36	13	7	184.6	19	205
37	13	7	185.1	19	205
38	13	7	205.6	20	229
39	12	6	198.7	20	220
40	12	6	204.8	20	226
41	11	5	198.3	20	220
42	11	5	185.0	19	205
43	11	5	203.3	20	226
44	10	4	198.2	20	220
45	10	4	204.1	20	226
46	17	11	204.9	20	229
47	17	11	185.4	19	205
48	17	11	184.2	19	205
49	17	11	205.0	20	226
50	18	12	199.5	20	220
51	18	12	200.6	20	220
52	18	12	204.8	20	229
AGGREGATE			5732.6	570	6343
TOTAL AGGREGATE			10274.5	1023	11361

Accepted as to Forms 1 and 2 this 18th day of May 1990.

Superintendent of Real Estate

STATUTORY DECLARATION

We, the undersigned do solemnly declare that:

1) We, the undersigned are the Owner-Developer:

2) The strata plan is entirely for residential use.

We make this solemn declaration conscientiously believing it to be true and knowing that it is of the same force and effect as if made under oath.

Declared before me at Richmond this 18th day of May 1990.

A Commissioner for taking affidavits within the Province of British Columbia.

Approved as Phase 2 of a 2 Phase Strata Plan under the Condominium Act this 20th day of May 1990.

Municipal Approving Officer for the Municipality of Surrey

OWNER: CARTWRIGHT HOLDINGS LTD. (INCORPORATION NO. 113813)

AUTHORIZED SIGNATORY

AUTHORIZED SIGNATORY

MORTGAGEE:

S-244 HOLDINGS LTD. (INC. NO. 382227)

AUTHORIZED SIGNATORY

AUTHORIZED SIGNATORY

VANCOUVER CITY SAVINGS CREDIT UNION

AUTHORIZED SIGNATORY

AUTHORIZED SIGNATORY

WITNESS

ADDRESS OF WITNESS

OCCUPATION OF WITNESS

WITNESS

ADDRESS OF WITNESS

OCCUPATION OF WITNESS

WITNESS

ADDRESS OF WITNESS

OCCUPATION OF WITNESS

I, D.G. Huxley, of Abbotsford, B.C., a British Columbia Land Surveyor, hereby certify that the buildings shown in this strata plan has not, as of the 10th day of May 1990, been previously occupied. Dated at Surrey, B.C., this 17th day of May 1990.

D.G. Huxley, B.C.L.S.

File: 89-A-2747

CONDOMINIUM ACT

Second Sheet, Sheet 3 of 12 Sheets

STRATA PLAN NW 3143

PHASE 2

STRATA LOT NO.	BLOCK NO.	SHEET NO.	AREA (sqm)	FORM 1	FORM 2
				SCHEDULE OF UNIT ENTITLEMENT UNIT ENTITLEMENT	SCHEDULE OF INTEREST UPON DESTRUCTION INTEREST UPON DESTRUCTION
24	16	10	204.4	20	229
25	16	10	190.3	19	210
26	16	10	192.5	19	210
27	16	10	204.8	20	226
28	15	9	204.3	20	226
29	15	9	188.6	19	205
30	15	9	198.6	20	220
31	14	8	204.4	20	229
32	14	8	190.9	19	210
33	14	8	192.5	19	210
34	14	8	204.8	20	226
35	13	7	204.8	20	226
36	13	7	184.6	19	205
37	13	7	185.1	19	205
38	13	7	205.6	20	229
39	12	6	198.7	20	220
40	12	6	204.8	20	226
41	11	5	198.3	20	220
42	11	5	185.0	19	205
43	11	5	203.3	20	226
44	10	4	188.2	20	220
45	10	4	204.1	20	226
46	17	11	204.9	20	229
47	17	11	185.4	19	205
48	17	11	184.2	19	205
49	17	11	205.0	20	226
50	18	12	199.5	20	220
51	18	12	200.6	20	220
52	18	12	204.8	20	229
AGGREGATE			5732.6	570	6343
TOTAL AGGREGATE			10274.5	1023	11361

Accepted as to Forms 1 and 2
this 18 day of May 1990.

[Signature]
Superintendent of Real Estate

STATUTORY DECLARATION

We, the undersigned do solemnly declare that:

- 1) We, the undersigned are the Owner-Developer;
- 2) The strata plan is entirely for residential use.

We make this solemn declaration conscientiously believing it to be true and knowing that it is of the same force and effect as if made under oath.

Declared before me at Richmond
this 18 day of May 1990.

A Commissioner for taking affidavits within the Province of British Columbia.

Approved as Phase 2 of a 2 Phase Strata Plan under the Condominium Act this 20 day of May 1990.

[Signature]
Municipal Approving Officer for the Municipality of Surrey

OWNER:
CARTWRIGHT HOLDINGS LTD.
(INCORPORATION NO. 113813)

AUTHORIZED SIGNATORY
[Signature]

AUTHORIZED SIGNATORY

MORTGAGEE:

S-244 HOLDINGS LTD.
(INC. NO. 332227)

AUTHORIZED SIGNATORY
[Signature]

AUTHORIZED SIGNATORY

VANCOUVER CITY SAVINGS CREDIT UNION

AUTHORIZED SIGNATORY
[Signature]

AUTHORIZED SIGNATORY
[Signature]

WITNESS

ADDRESS OF WITNESS

OCCUPATION OF WITNESS

WITNESS

ADDRESS OF WITNESS

OCCUPATION OF WITNESS

WITNESS

ADDRESS OF WITNESS

OCCUPATION OF WITNESS

I, D.G. Huxley, of Abbotsford, B.C., a British Columbia Land Surveyor, hereby certify that the buildings shown in this strata plan has not, as of the 18th day of May, 1990, been previously occupied. Dated at Surrey, B.C., this 17th day of May, 1990.

[Signature]
D.G. Huxley, B.C.L.S.

File: 89-A-2747

Plan #: NWS3143 App #: N/A Crt #: (Altered)

RCVD: 1998-02-12 ROST: 2013-11-18 21:16:02

FLOOR PLANS & CROSS-SECTION

Sheet 5 of 12 Sheets

STRATA PLAN NW 3143

PHASE 2

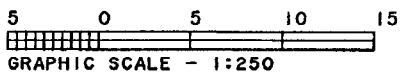

**BLOCK II
FIRST FLOOR**

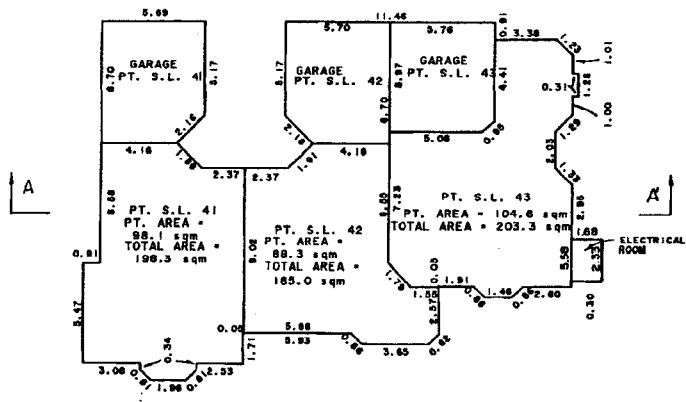

SECOND FLOOR

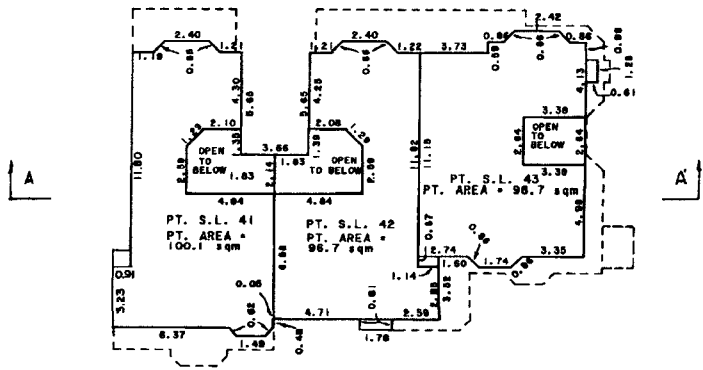

SECTION A - A'

PT. S.L. 41	PT. S.L. 42	PT. S.L. 43
PT. S.L. 41	PT. S.L. 42	PT. S.L. 43
⊙	⊙	⊙

SECOND FLOOR

GROUND FLOOR

CRAWL SPACE

DATED THIS 17th DAY OF
May, 1990.

D.H. B.C.L.S.

FILE: 89-A-2747-22

Plan #: NWS3143 App #: N/A Cht #: (Altered)

RCVD: 1998-02-12 RQST: 2013-11-18 21:16:02

FLOOR PLANS & CROSS-SECTION

Sheet 6 of 12 Sheets

STRATA PLAN NW 3143

PHASE 2

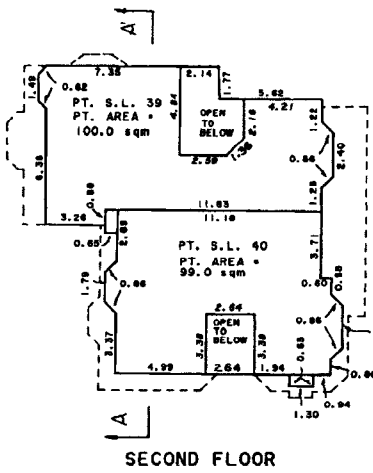
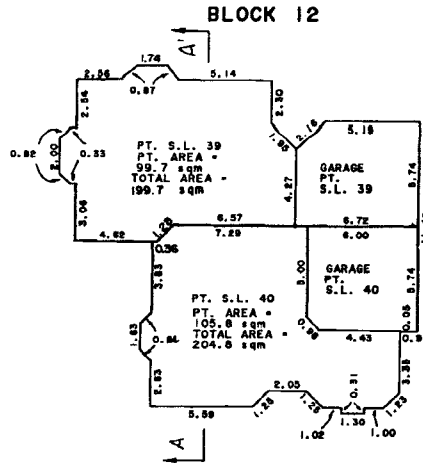

PT. S.L. 40	PT. S.L. 39
PT. S.L. 40	PT. S.L. 39
⊕	⊕

SECOND FLOOR

GROUND FLOOR

CRAWL SPACE

SECTION A - A'

DATED THIS 17th DAY OF May, 1990.

DK. B.C.L.S.
FILE: 89-A-2747-23

FLOOR PLANS & CROSS-SECTION

Sheet 7 of 12 Sheets

STRATA PLAN NW 3143

PHASE 2



BLOCK 13

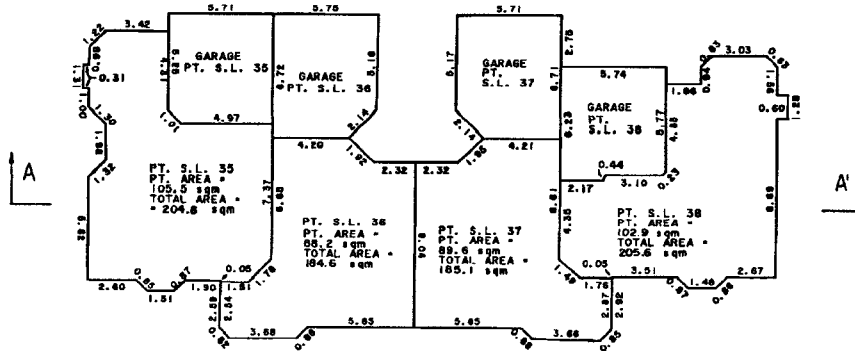

FIRST FLOOR

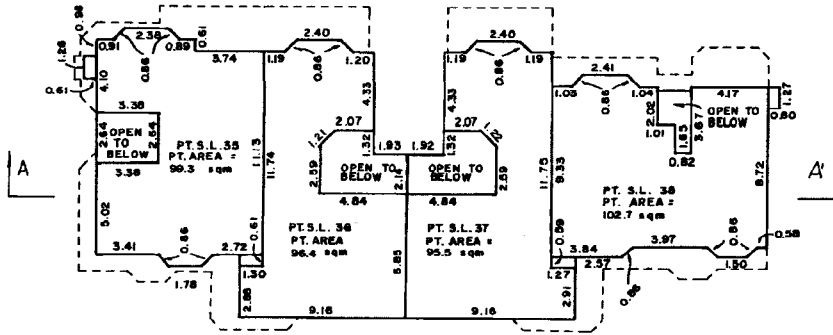

SECOND FLOOR

PT. S.L. 35	PT. S.L. 36	PT. S.L. 37	PT. S.L. 38
PT. S.L. 35	PT. S.L. 36	PT. S.L. 37	PT. S.L. 38
⊙	⊙	⊙	⊙

SECOND FLOOR

GROUND FLOOR

CRAWL SPACE

SECTION A - A'

DATED THIS 17th DAY OF May, 1990.

D.H. B.C.L.S.

FILE: 89-A-2747-24

Plan #: NWS3143 App #: N/A Crl #: (Altered)

RCVD: 1998-02-12 RQST: 2013-11-18 21:16:02

FLOOR PLANS & CROSS SECTION

Sheet 8 of 12 Sheets

STRATA PLAN NW3143

PHASE 2



BLOCK 14

FIRST FLOOR

SECOND FLOOR

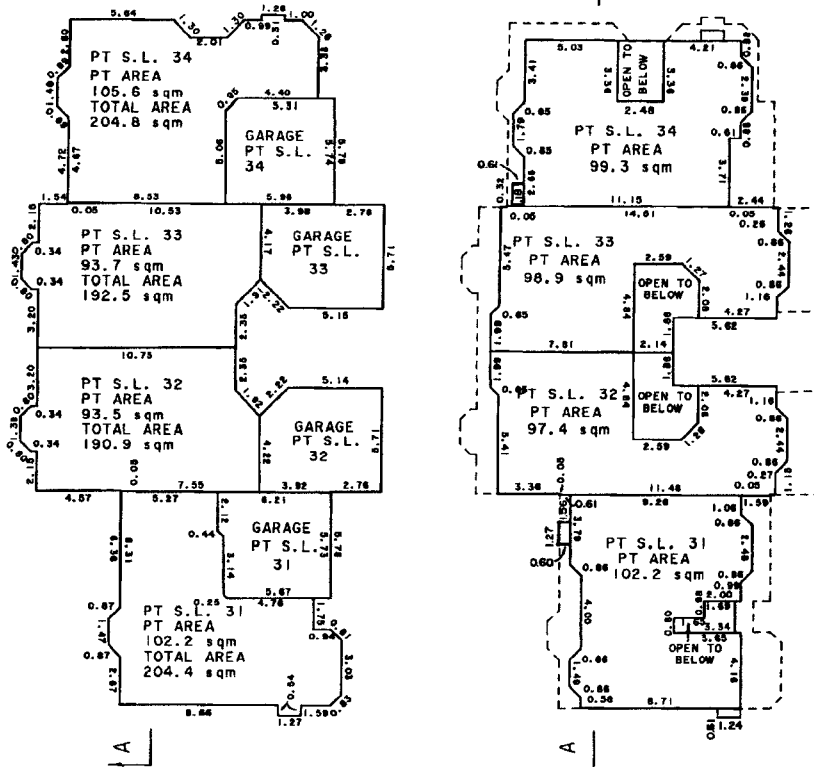

SECTION A - A'

PT.S.L.31	PT.S.L.32	PT.S.L.33	PT.S.L.34
PT.S.L.31	PT.S.L.32	PT.S.L.33	PT.S.L.34
⊙	⊙	⊙	⊙

SECOND FLOOR
GROUND FLOOR
CRAWL SPACE

DATED THIS 17th DAY OF May 1990.

D.H. B.C.L.S.

FILE: 89-A-2747-25

Plan #: NWS3143 App #: N/A Ctr #: (Altered)

RCVD: 1998-02-12 ROST: 2013-1-18 21:16:02

FLOOR PLANS & CROSS-SECTION

Sheet 9 of 12 Sheets

STRATA PLAN NW 3143

PHASE 2



BLOCK 15

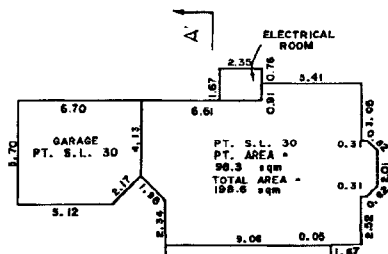

FIRST FLOOR

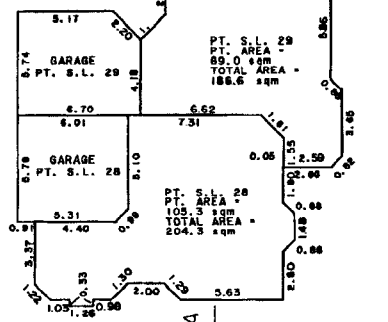

SECOND FLOOR

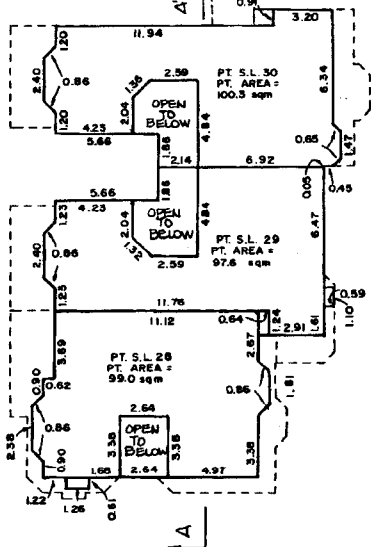

PT. S.L. 28	PT. S.L. 29	PT. S.L. 30
PT. S.L. 28	PT. S.L. 29	PT. S.L. 30
⊙	⊙	⊙

SECTION A - A'

SECOND FLOOR
GROUND FLOOR
CRAWL SPACE

DATED THIS 17th DAY OF
May, 1990.

D.K. B.C.L.S.
FILE: 89-A-2747-26

Plan #: NWS3143 App #: N/A Crt #: (Altered)

RCVD: 1998-02-12 ROST: 2013-11-18 21:16:02

FLOOR PLANS & CROSS SECTION

Sheet 10 of 12 Sheets

STRATA PLAN NW3143

PHASE 2



BLOCK 16

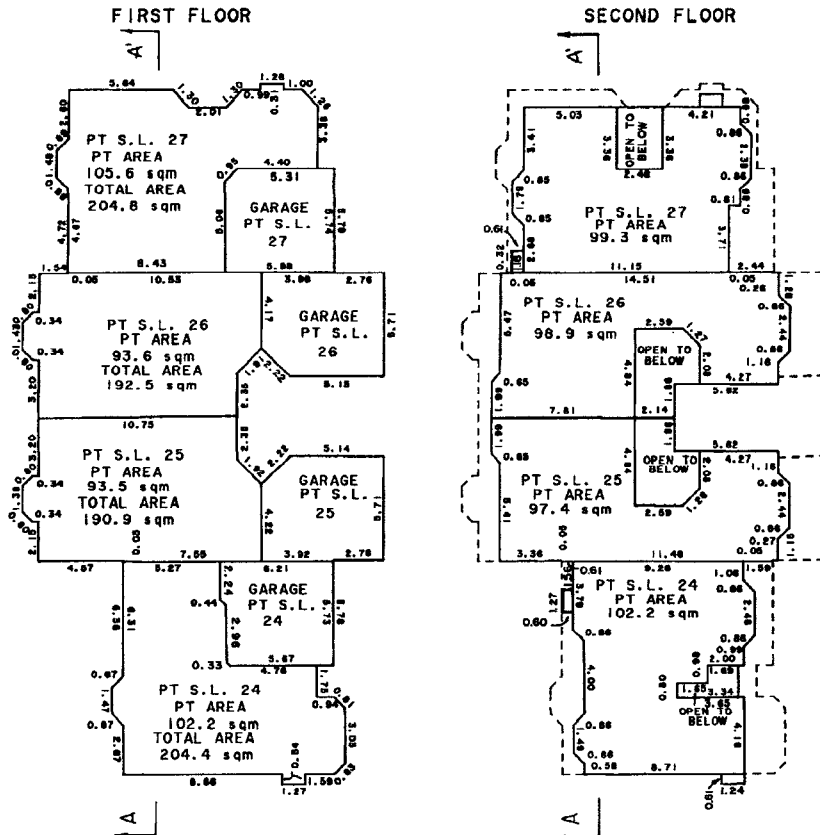

SECTION A - A'

PT.SL. 24	PT.SL. 25	PT.SL. 26	PT.SL. 27	SECOND FLOOR
PT.SL. 24	PT.SL. 25	PT.SL. 26	PT.SL. 27	GROUND FLOOR
⊙	⊙	⊙	⊙	CRAWL SPACE

DATED THIS 11th DAY OF May 1990.

D.H. B.C.L.S.

FILE: 89-A-2747-27

Plan #: NWS3143 App #: N/A Crt #: (Altered)

RCVD: 1998-02-12 RQST: 2013-11-18 21:16:02

FLOOR PLANS & CROSS-SECTION

Sheet 11 of 12 Sheets
STRATA PLAN NW 3143
 PHASE 2

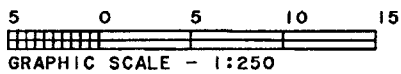

BLOCK 17

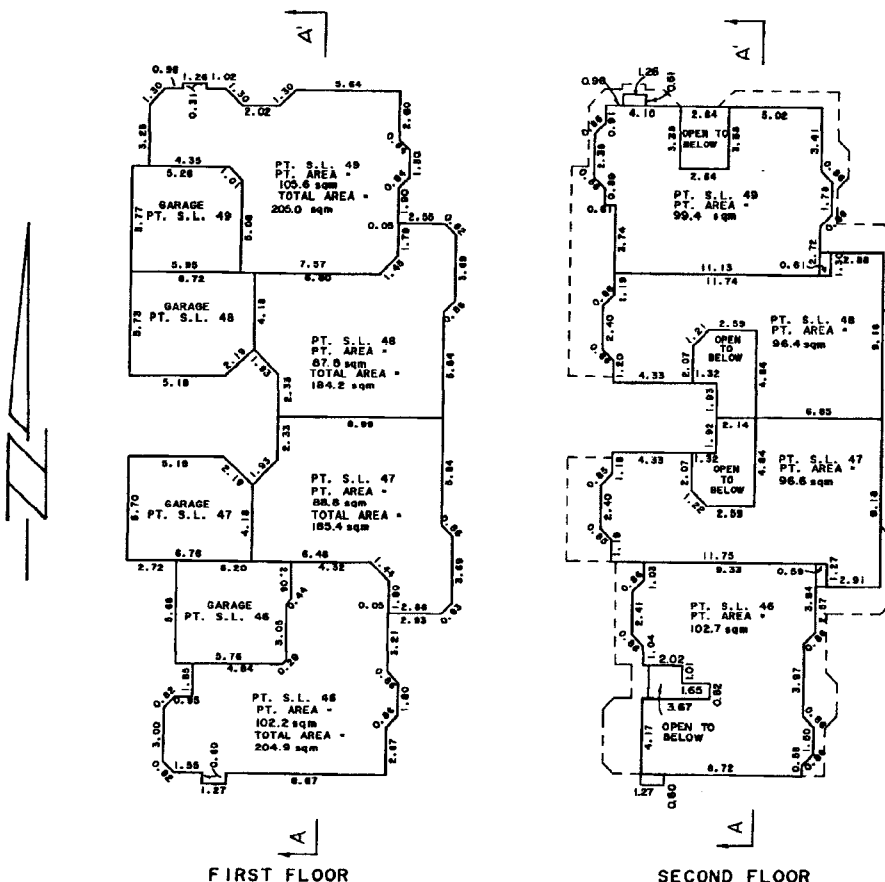

FIRST FLOOR

SECOND FLOOR

PT. SL. 46	PT. SL. 47	PT. SL. 48	PT. SL. 49
PT. SL. 46	PT. SL. 47	PT. SL. 48	PT. SL. 49
⊙	⊙	⊙	⊙

SECOND FLOOR
 GROUND FLOOR
 CRAWL SPACE

SECTION A - A'

DATED THIS 17th DAY OF
 May, 1990.

D.H. B.C.L.S.
 FILE: 89-A-2747-28

Plan #: NWS3143 App #: N/A Ctr #: (Altered)

RCVD: 1998-02-12 RQST: 2013-11-18 21:16:02

FLOOR PLANS & CROSS-SECTION

Sheet 12 of 12 Sheets

STRATA PLAN NW 3143

PHASE 2



BLOCK 18

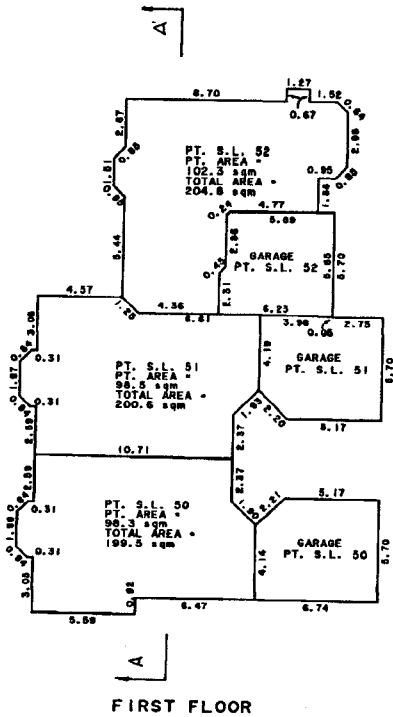

FIRST FLOOR

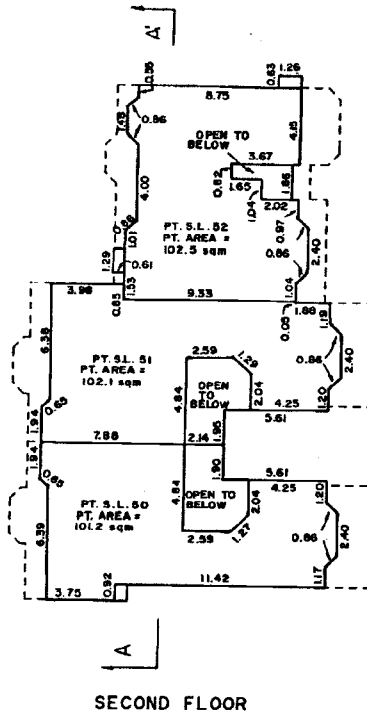

SECOND FLOOR

PT. S.L. 50	PT. S.L. 51	PT. S.L. 52
PT. S.L. 50	PT. S.L. 51	PT. S.L. 52
⊙	⊙	⊙

SECOND FLOOR

GROUND FLOOR

CRAWL SPACE

SECTION A - A'

DATED THIS 17th DAY OF May, 1990.

D.H B. C. L. S.

FILE: 89-A-2747-29

Plan #: NWS3143 App #: N/A Crl #: (Altered)

RCVD: 1998-02-12 ROST: 2013-11-18 21.16.02